

**REPAIR PARTS MANUAL**  
**MODEL NO. LZ13592RBK (96061011900)**  
**Lawn Tractor**

---

**LAZER<sup>®</sup>**

# HOW TO USE THIS MANUAL

This manual is designed to provide the customer with a means to identify the parts on his/her tractor when ordering repair parts. The illustrations may or may not represent the actual assemblies; therefore, it is not recommended to use this manual as a guide to assemble or disassemble the tractor. Some hardware and parts are drawn larger in order to more readily identify them.

Each tractor has its own model number.

The model number for your tractor can be found on the fender under the seat.

When ordering parts, always give the following information:

- Product - "Tractor"
- Model Number - "LZ13592RBK (96061011900)"
- Part Number
- Part Description

## TABLE OF CONTENTS



SCHEMATIC .....	3
ELECTRICAL.....	4-5
CHASSIS.....	6-7
DRIVE.....	8-9
STEERING .....	10-11
SEAT .....	12
DECALS.....	13
ENGINE.....	14
MOWER LIFT.....	15
MOWER DECK .....	16-17
BAGGER .....	18

# TRACTOR- -MODEL NO. LZ13592RBK (96061011900), PRODUCT NO. 960 61 01-19 SCHEMATIC

03055\_197436 (WITH LIGHTS)

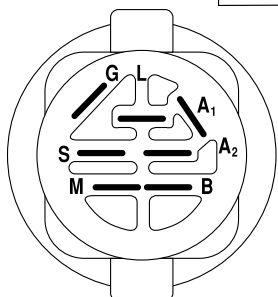
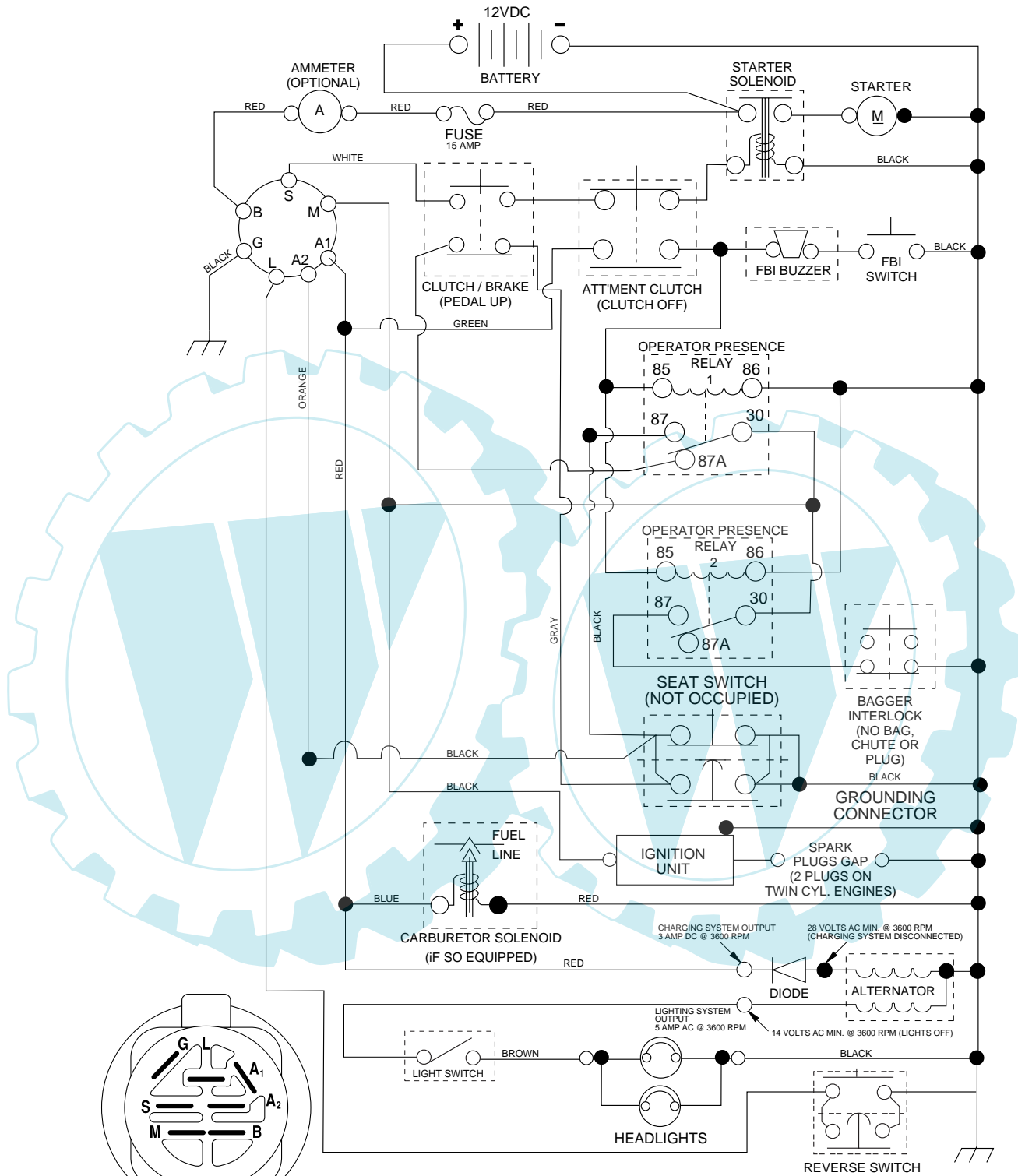

**IGNITION SWITCH**

POSITION	CIRCUIT "MAKE"
OFF	M+G+A1
RUN/OVERRIDE	B+A1
RUN	B+A1 L+A2
START	B + S + A1

**WIRING INSULATED CLIPS**

**NOTE: IF WIRING INSULATED CLIPS WERE REMOVED FOR SERVICING OF UNIT, THEY SHOULD BE REPLACED TO PROPERLY SECURE YOUR WIRING.**

REMOVABLE CONNECTIONS

NON-REMOVABLE CONNECTIONS

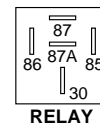

**RELAY**

03055

# REPAIR PARTS

TRACTOR- -MODEL NO. LZ13592RBK (96061011900), PRODUCT NO. 960 61 01-19  
ELECTRICAL

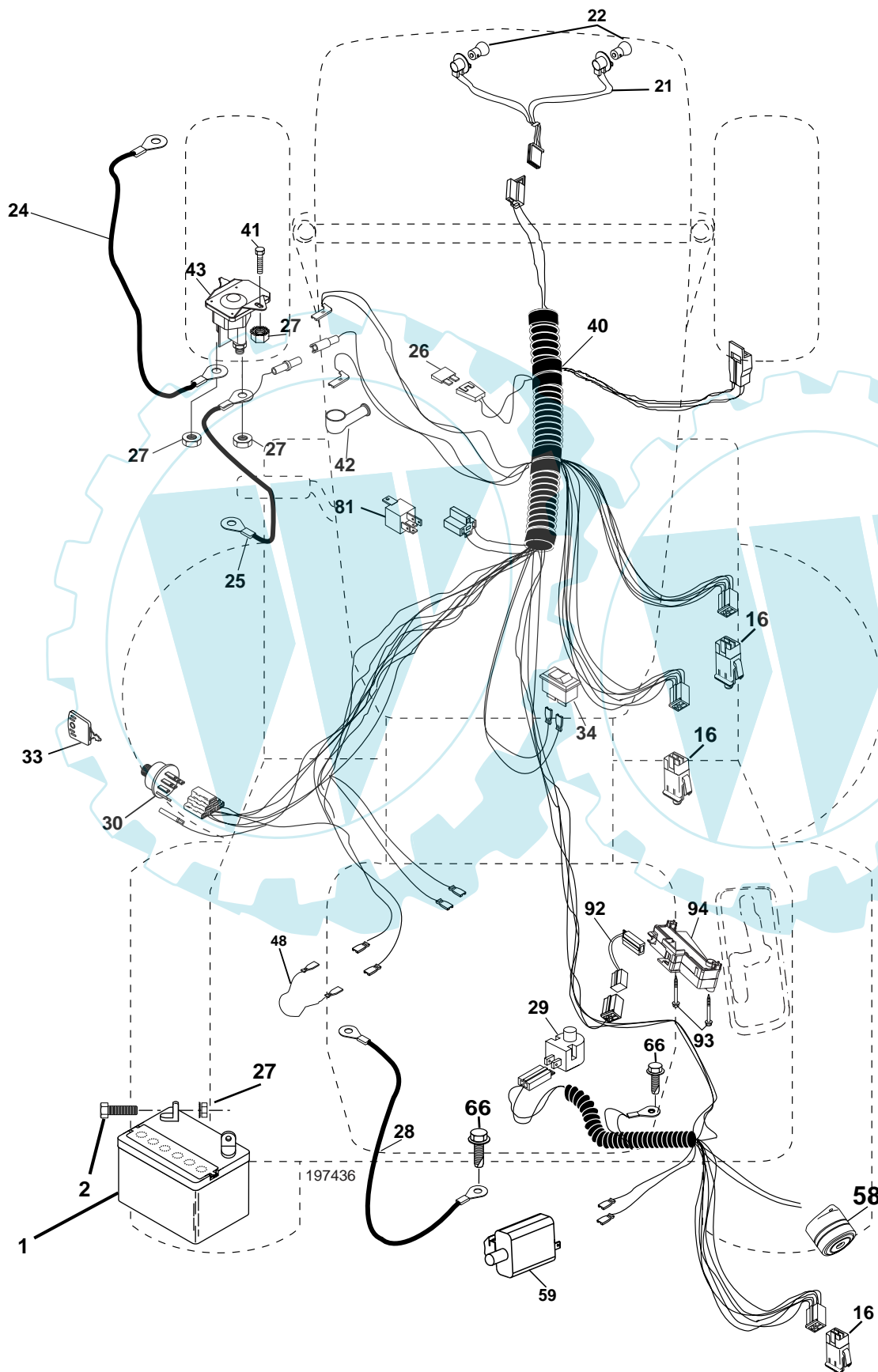

## REPAIR PARTS

TRACTOR- -MODEL NO. LZ13592RBK (96061011900), PRODUCT NO. 960 61 01-19  
ELECTRICAL

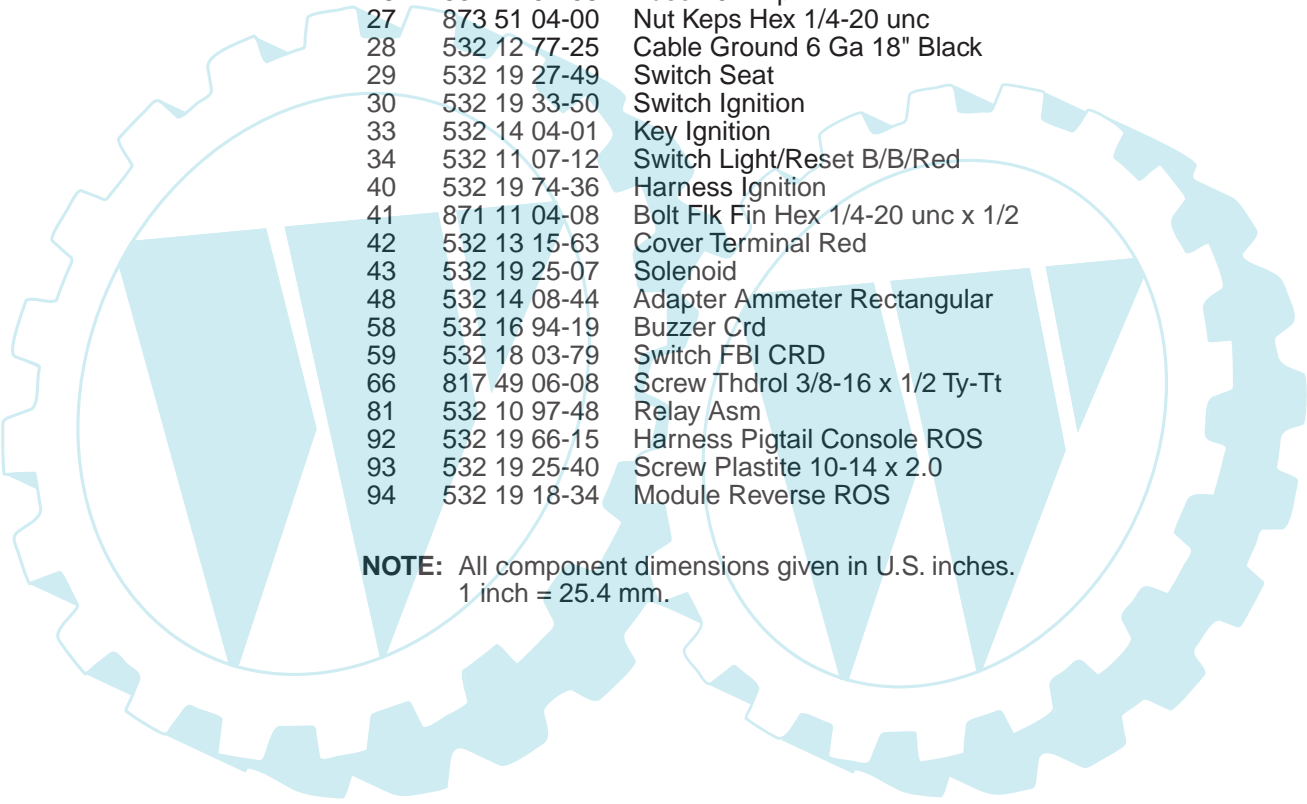

KEY NO.	PART NO.	DESCRIPTION
1	532 16 34-65	Battery
2	874 76 04-12	Bolt Hex Hd 1/4-20 unc x 3/4
16	532 17 61-38	Switch Interlock Push-In
21	532 18 37-59	Harness Asm. Light
22	532 00 41-52	Bulb
24	532 12 47-80	Cable Starter 6 Ga. 11" Red
25	532 16 59-87	Cable Battery Crd 56" Red
26	532 17 51-58	Fuse 20 Amp
27	873 51 04-00	Nut Keps Hex 1/4-20 unc
28	532 12 77-25	Cable Ground 6 Ga 18" Black
29	532 19 27-49	Switch Seat
30	532 19 33-50	Switch Ignition
33	532 14 04-01	Key Ignition
34	532 11 07-12	Switch Light/Reset B/B/Red
40	532 19 74-36	Harness Ignition
41	871 11 04-08	Bolt Flk Fin Hex 1/4-20 unc x 1/2
42	532 13 15-63	Cover Terminal Red
43	532 19 25-07	Solenoid
48	532 14 08-44	Adapter Ammeter Rectangular
58	532 16 94-19	Buzzer Crd
59	532 18 03-79	Switch FBI CRD
66	817 49 06-08	Screw Thdrol 3/8-16 x 1/2 Ty-Tt
81	532 10 97-48	Relay Asm
92	532 19 66-15	Harness Pigtail Console ROS
93	532 19 25-40	Screw Plastite 10-14 x 2.0
94	532 19 18-34	Module Reverse ROS

**NOTE:** All component dimensions given in U.S. inches.  
1 inch = 25.4 mm.

# REPAIR PARTS

TRACTOR- -MODEL NO. LZ13592RBK (96061011900), PRODUCT NO. 960 61 01-19  
CHASSIS AND ENCLOSURES

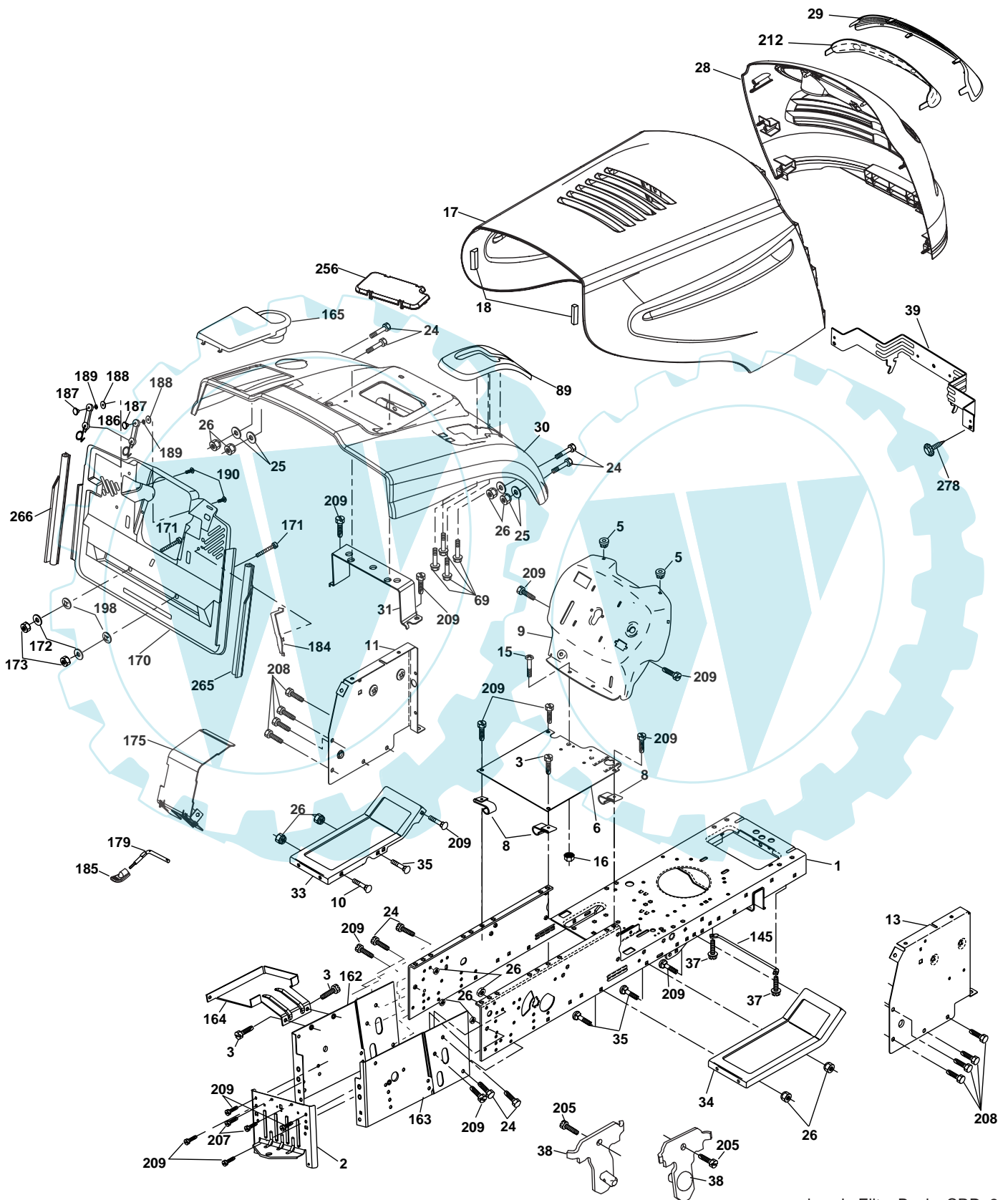

chassis-Elite\_Basic\_CRD\_3

# REPAIR PARTS

## TRACTOR- -MODEL NO. LZ13592RBK (96061011900), PRODUCT NO. 960 61 01-19 CHASSIS AND ENCLOSURES

KEY NO.	PART NO.	DESCRIPTION	KEY NO.	PART NO.	DESCRIPTION
1	532 17 46-20	Chassis	163	532 18 03-83	Bracket Exten Chassis Rh CRD
2	532 18 03-84	Drawbar	164	532 16 56-05	Support Battery CRD
3	817 06 06-12	Screw 3/8-16 x .75	165	532 18 13-56	Cover Battery CRD Lt
5	532 15 52-72	Bumper Hood/Dash	170	532 19 94-88	Backplate CRD
6	532 18 44-19	Saddle	171	872 14 06-20	Bolt Rdhd Sqnk 3/8-16 x 2-1/2 Gr. 5
8	532 12 64-71	Clip Insulator 13/32 Mtg. Hole	172	819 13 20-16	Washer 13/32 x 1-1/4 x 16 Ga.
9	532 19 46-88	Dash	173	873 51 06-00	Nut, Keps Hex 3/8-16 unc
10	872 14 06-08	Bolt, Carriage 3/8-16 x 3/4	175	532 18 82-03	Trap Door CRD
11	532 17 49-96	Panel, Dash, L.H.	179	532 18 82-02	Rod Pivot FBI CRD
13	532 18 69-52	Panel, Asm. Dash R.H.	184	532 17 46-62	Bracket Actuator Bagger CRD
15	874 18 05-12	Screw, Machine, Truss Head 5/16-18 unc x 3/4	185	532 18 11-01	Knob Rod
16	873 51 05-00	Nut	186	532 16 07-93	Latch Asm Multch Bagger
17	532 18 67-07	Hood Assembly	187	532 12 50-04	Nut Weld .327/.304 #10-24
18	532 18 49-21	Bumper Hood	188	819 06 12-16	Washer #10
24	874 78 06-16	Bolt	189	810 07 10-00	Washer Lock #10
25	819 13 13-12	Washer 13/32 x 13/16 x 12 Ga.	190	871 08 10-10	Screw Pan Hd Phillips 10-24 x 5/8
26	873 80 06-00	Nut	198	532 16 89-37	Nut Push
28	532 18 38-26	Grille Lens Asm (Includes Key #'s 29, 212)	205	817 49 06-08	Screw 3/8-16 x 1/2
29	532 18 98-37	Lens Grille	207	817 67 05-08	Screw 5/16-18 x 1/2
30	532 19 73-44	Fender	208	817 67 06-08	Screw Thdrol 3/8-16 x 1/2
31	532 16 51-56	Bracket, Fender Support	209	817 00 06-12	Screw Hex Wsh Thdrol 3/8-16 x 3/4
33	532 18 11-93	Footrest, L.H.	212	532 18 38-23	Insert Lens Reflective
34	532 18 11-94	Footrest, R.H.	256	532 18 13-61	Cover Fender Rack CRD
35	872 11 06-06	Bolt	265	532 18 57-04	Seal RH Side Bagger
37	817 49 05-08	Screw Thdrol 5/16-18 x 1/2 TYT	266	532 18 57-03	Seal LH Side Bagger
38	532 18 17-48	Bracket Asm Pivot Mower Rear	278	532 19 16-11	Screw 10 x 3/4 Single Lead Hex
39	532 17 47-14	Bracket Pivot	--	532 00 54-79	Plug, Button
69	532 14 24-32	Screw Hex 1/4-1/2			
89	532 19 73-39	Console			
145	532 15 65-24	Rod Pivot Chassis/Hood			
162	532 18 03-82	Bracket Exten Chassis Lh CRD			

**NOTE:** All component dimensions given in U.S. inches.  
1 inch = 25.4 mm.

# REPAIR PARTS

TRACTOR- -MODEL NO. LZ13592RBK (96061011900), PRODUCT NO. 960 61 01-19  
DRIVE

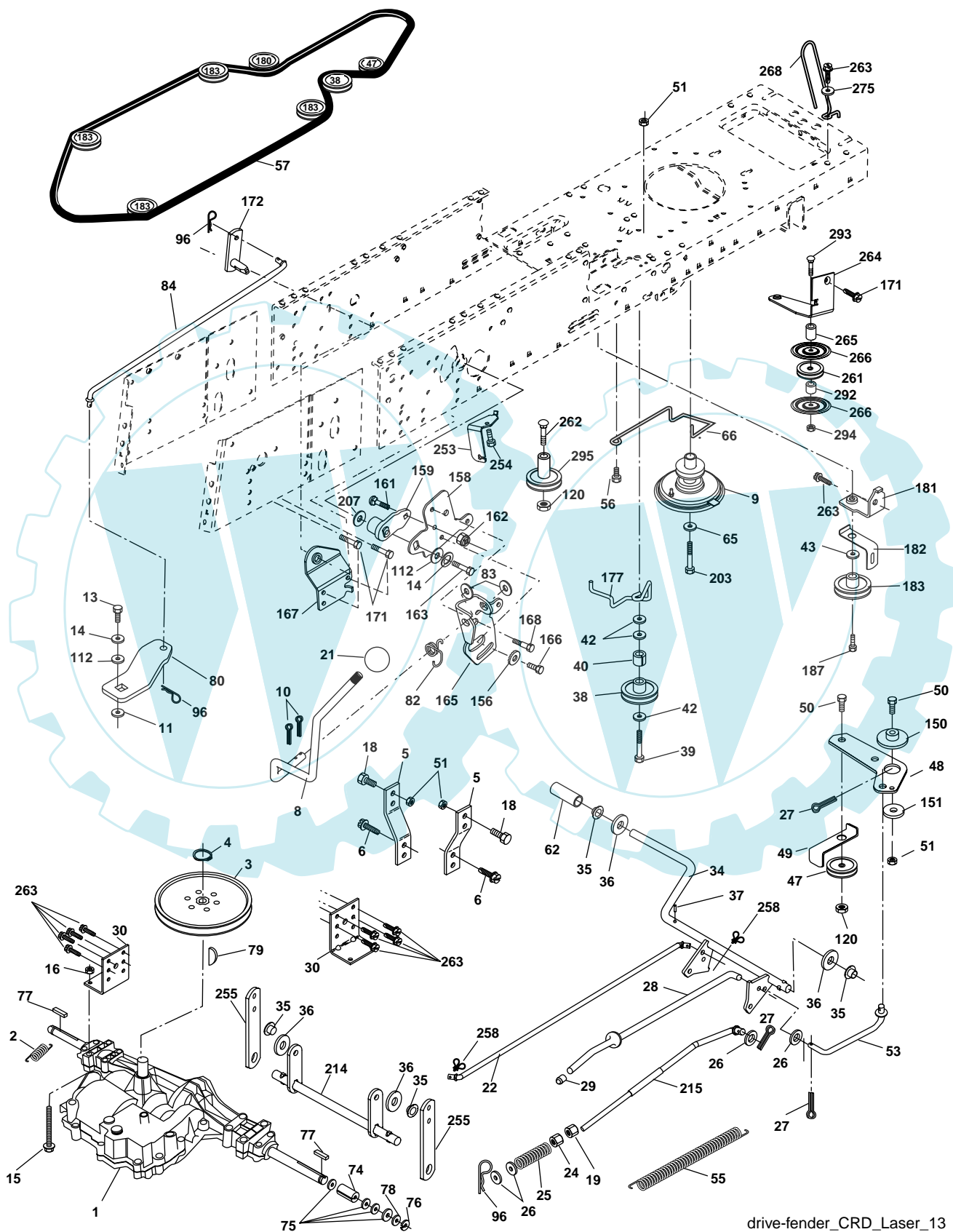

drive-fender\_CRD\_Laser\_13



# REPAIR PARTS

TRACTOR- -MODEL NO. LZ13592RBK (96061011900), PRODUCT NO. 960 61 01-19  
DRIVE

KEY NO.	PART NO.	DESCRIPTION	KEY NO.	PART NO.	DESCRIPTION
1	-----	Transaxle Peerless 206-546 Order parts from transaxle manufacturer	79	532 12 50-96	Key Woodruff
2	532 14 66-82	Spring Brake Return	80	532 14 50-90	Arm Shift PMST 20" Tires
3	532 16 59-99	Pulley Transaxle	82	532 16 57-11	Spring, Torsion
4	812 00 00-28	Ring Retainer #5100-62	83	819 17 12-16	Washer 17/32 x 3/4 x 16 Ga.
5	532 12 15-20	Strap torque 30 degrees	84	532 16 56-21	Link Shift CRD Pmst 18" Tires
6	817 06 05-12	Screw 5/16-18 x 3/4	96	532 12 47-88	Spring, Retainer 1"
8	532 19 27-06	Rod Shift Fender Adjust Lt	112	819 09 12-10	Washer 9/32 x 3/4 x 10 Ga.
9	532 18 03-54	Clutch Asm Noram	120	873 90 06-00	Nut Lock 3/8-16
10	876 02 04-16	Pin, Cotter 1/8 x 1	150	532 16 58-50	Bushing, Bellcrank Grnd Dr
11	532 10 57-01	Washer Plate Shf .3888 sq hole	151	819 13 32-10	Washer 13/32 x 2 x 10 Ga.
13	874 55 04-12	Bolt 1/4-28 unF Gr. 8 w/patch	156	532 16 60-02	Washer Srrd 5/16 ID x 1.125
14	810 04 04-00	Washer, Lock Hvy Helical	158	532 16 55-89	Bracket Shift Mount
15	874 49 05-44	Bolt Hex FGHD 5/16-18 x Gr. 5	159	532 18 39-00	Hub Tapered Flange Shift Lt
16	873 80 05-00	Nut, Lock Hex w/Ins 5/16-18 unc	161	872 14 04-06	Bolt Rdhd Sqnk 1/4-20 x 3/4 Gr 5
18	874 78 06-16	Bolt Hex 3/8-16 UNC x 1 Gr. 5	162	873 68 04-00	Nut Crownlock 1/4-20 unc
19	873 80 06-00	Nut, Lock Hex w/Wsh 3/8-16 unc	163	874 78 04-16	Bolt Hex Fin 1/4-20 unc x 1 Gr 5
21	532 10 69-33	Knob Round 1/2-13 unc Blk	165	532 16 56-23	Bracket Pivot Lever
22	532 17 56-07	Rod, Brake CRD Main	166	817 49 05-10	Screw 5/16-18 x 5/8
24	873 35 06-00	Nut	167	532 16 55-88	Bracket Support Shift CRD
25	532 10 68-88	Spring, Rod, Brake	168	532 16 54-92	Bolt Shoulder 5/16-18 x .561
26	819 13 13-16	Washer 13/32 x 13/16 x 16 Ga.	171	817 49 06-08	Screw Thdrol 3/8-16 x 1/2 Ty-Tt
27	876 02 04-12	Pin, Cotter 1/8 x 3/4	172	532 16 56-35	Shaft Asm Shift Front CRD PMST
28	532 17 57-65	Rod, Parking Brake	177	532 16 59-32	Keeper Flat Idler 3.06" CRD
29	532 07 16-73	Cap, Parking Brake	181	532 18 02-11	Bracket Idler Ground Drive CRD
30	532 17 49-73	Bracket, Mfg. Transaxle	182	532 18 26-82	Keeper Belt 2.5" Od V-Idler CRD
34	532 17 55-78	Shaft, Asm Pedal Foot CRD	183	532 18 60-07	Pulley V-Idler 2.50" Od CRD
35	532 12 01-83	Bearing, Nylon	187	817 58 05-20	Screw 5/16-18 x 1.25
36	819 21 16-16	Washer 21/32 x 1 x 16 Ga.	203	871 17 07-80	Bolt Hex 7/16-20 x 5
37	532 12 49-63	Pin, Roll 3/16 x 1"	207	532 16 98-45	Washer Nylon
38	532 16 59-36	Pulley, Flat	214	532 17 56-09	Shaft Asm. Brake
39	874 76 06-44	Bolt Fin Hex 3/8-16 unc x 2-3/4	215	532 19 95-80	Rod Brake Secondary
40	532 12 49-65	Spacer, Split 395 x 59 Bzp	253	532 17 50-28	Bracket Cable Chassis
42	819 13 13-12	Washer 13/32 x 13/16 x 12 Ga.	254	817 00 06-16	Screw 3/8-16 x 1
43	819 11 10-12	Washer 11/32 x 5/8 x 12 Ga.	255	532 17 56-08	Brace Shaft Brake
47	532 12 77-83	Pulley, Idler, V Groove Plasic	258	532 17 80-62	Clip Retainer
48	532 15 44-07	Bellcrank Clutch Grnd Drv	261	532 13 14-94	Pulley Idler Flat Plated
49	532 12 32-05	Retainer, Belt Style Spring	262	872 11 06-22	Bolt Rdhd 3/8-16 unc x 2-3/4 Gr. 5
50	872 11 06-12	Bolt Carr Sh 3/8-16 x 1-1/2 Gr. 5	263	817 00 06-12	Screw Hex Wsh THDR 3/8-16 x 3/4
51	873 68 06-00	Nut, Crownlock 3/8-16 unc	264	532 19 76-08	Bracket Idler Chassis
53	532 19 96-52	Link, Clutch 7.66	265	532 18 20-13	Spacer Idler Chassis
55	532 10 57-09	Spring, Return, Clutch	266	532 18 20-61	Shield Idler
56	817 06 06-20	Screw 3/8-16 x 1-1/4	268	532 18 24-02	Guard Muffler OHV B&S RH
57	532 16 56-31	V-Belt Kev PMST CRD	275	819 13 16-14	Washer 13/32 x 1 x 14 Ga.
62	532 12 48-72	Cover, Pedal	292	532 40 02-71	Spacer Noram
65	810 04 07-00	Washer	293	872 14 06-28	Bolt Rdhd Sqnk 3/8-16 x 3-1/2
66	532 15 47-78	Keeper, Belt Engine F-Proof	294	532 19 70-33	Nut Jam 3/8-16
74	532 13 70-57	Spacer Axle	295	532 17 91-14	Pulley Idler Composite
75	532 12 17-49	Washer 25/32 x 1-1/4 x 16 Ga.			
76	812 00 00-01	Ring, E			
77	532 12 35-83	Key, Square			
78	532 12 17-48	Washer 25/32 x 1-5/8 x 16 Ga.			

**NOTE:** All component dimensions given in U.S. inches  
1 inch = 25.4 mm

# REPAIR PARTS

TRACTOR- -MODEL NO. LZ13592RBK (96061011900), PRODUCT NO. 960 61 01-19  
STEERING ASSEMBLY

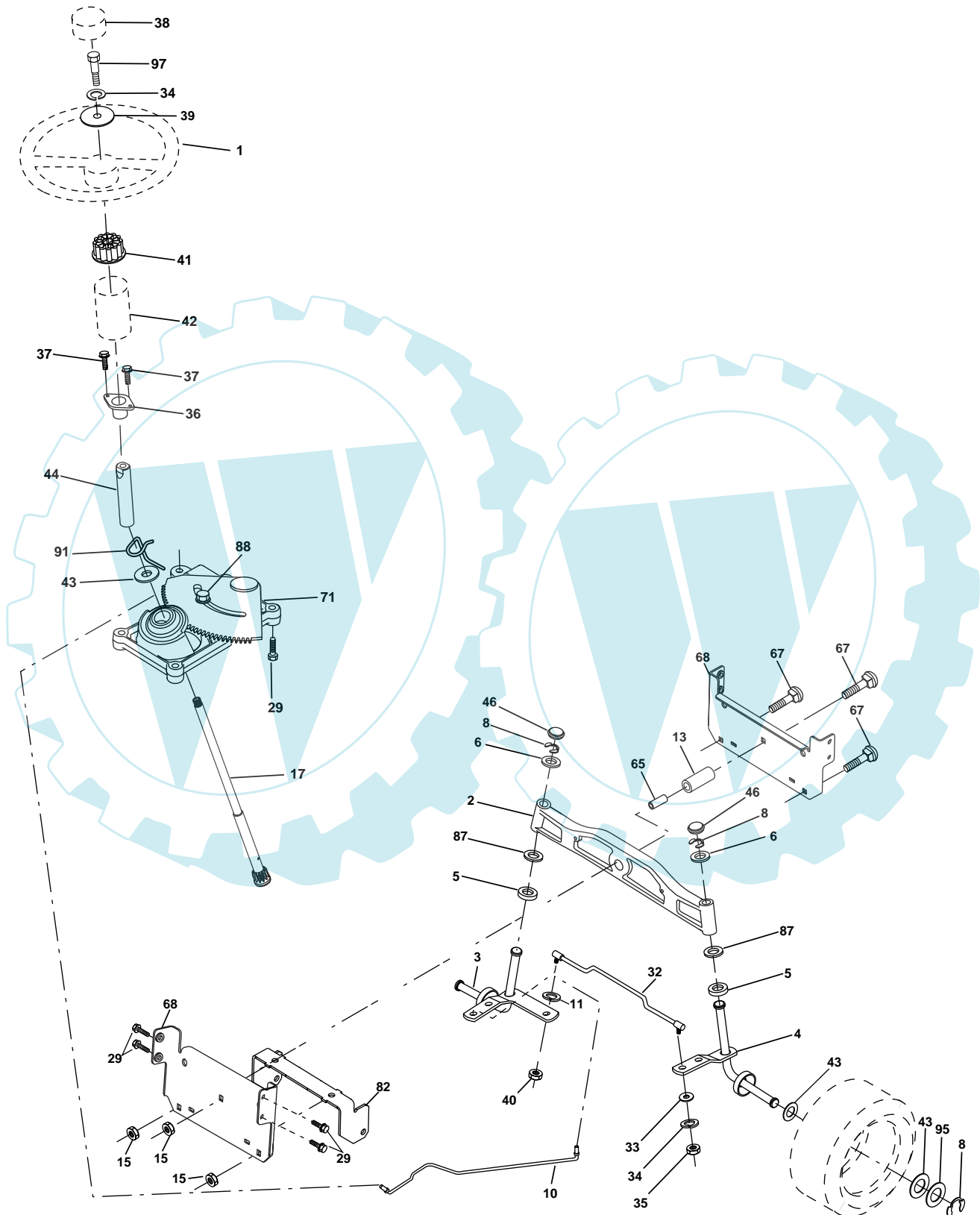

steering\_pl.lt\_60

## REPAIR PARTS

TRACTOR- -MODEL NO. LZ13592RBK (96061011900), PRODUCT NO. 960 61 01-19  
STEERING ASSEMBLY

KEY NO.	PART NO.	DESCRIPTION
1	532 18 67-80	Steering Wheel
2	532 18 47-06	Cast Iron Axle Assembly
3	532 16 98-40	Spindle Assembly, L.H.
4	532 16 98-39	Spindle Assembly, R.H.
5	532 12 49-31	Bearing, Race, Thrust, Hardened
6	532 12 17-48	Washer 25/32 x 1-5/8 x 16 Ga.
8	812 00 00-29	Ring, Klip
10	532 17 51-21	Link, Drag
11	810 04 06-00	Washer, Lock
13	532 13 65-18	Spacer Brg Axle Front
15	532 14 52-12	Nut, Hexflange Lock
17	532 19 07-53	Shaft, Steering
29	817 00 06-12	Screw, 3/8-16 x 3/4
32	532 17 01-62	Rod, Tie
33	819 11 12-16	Washer 11/32 x 3/4 x 16 Ga.
34	810 04 05-00	Washer Lock Hvy Hlcl Spr 5/16
35	873 54 05-00	Nut Crownlock 5/16-24 unf
36	532 15 50-99	Bushing, Steering
37	532 15 29-27	Screw TT #10-32 x 5 x 3/8 Flange
38	532 19 29-16	Cap Wheel Steer
39	819 11 38-12	Washer 11/32 x 2-3/8 x 12 Ga.
40	873 54 06-00	Nut Crownlock 3/8-24
41	532 18 67-37	Adaptor, Steering Wheel
42	532 16 96-33	Boot, Steering Dash P/L Mtl
43	532 12 17-49	Washer 25/32 x 1-1/4 x 16 Ga.
44	532 19 07-52	Extension Steering
46	532 12 12-32	Cap, Spindle
65	532 16 03-67	Spacer Brace Axle
67	872 11 06-18	Bolt Rdhd Sq 3/8-16 unc x 2-1/4
71	532 17 51-46	Steering Asm.
68	532 16 98-27	Brace Axle
82	532 19 99-78	Bracket Susp Chassis Front
87	532 17 39-66	Washer Flat .781 x 1-1/2 x .14
88	532 17 51-18	Bolt Shoulder 7/16-20 unc
91	532 17 55-53	Clip Steering
95	532 18 89-67	Washer Harden .793 x 1.637 x 060
97	874 78 05-64	Bolt 5/16-18 unc x 4"L Gr. 5

**NOTE:** All component dimensions given in U.S. inches.  
1 inch = 25.4 mm.

# REPAIR PARTS

TRACTOR- -MODEL NO. LZ13592RBK (96061011900), PRODUCT NO. 960 61 01-19  
SEAT ASSEMBLY

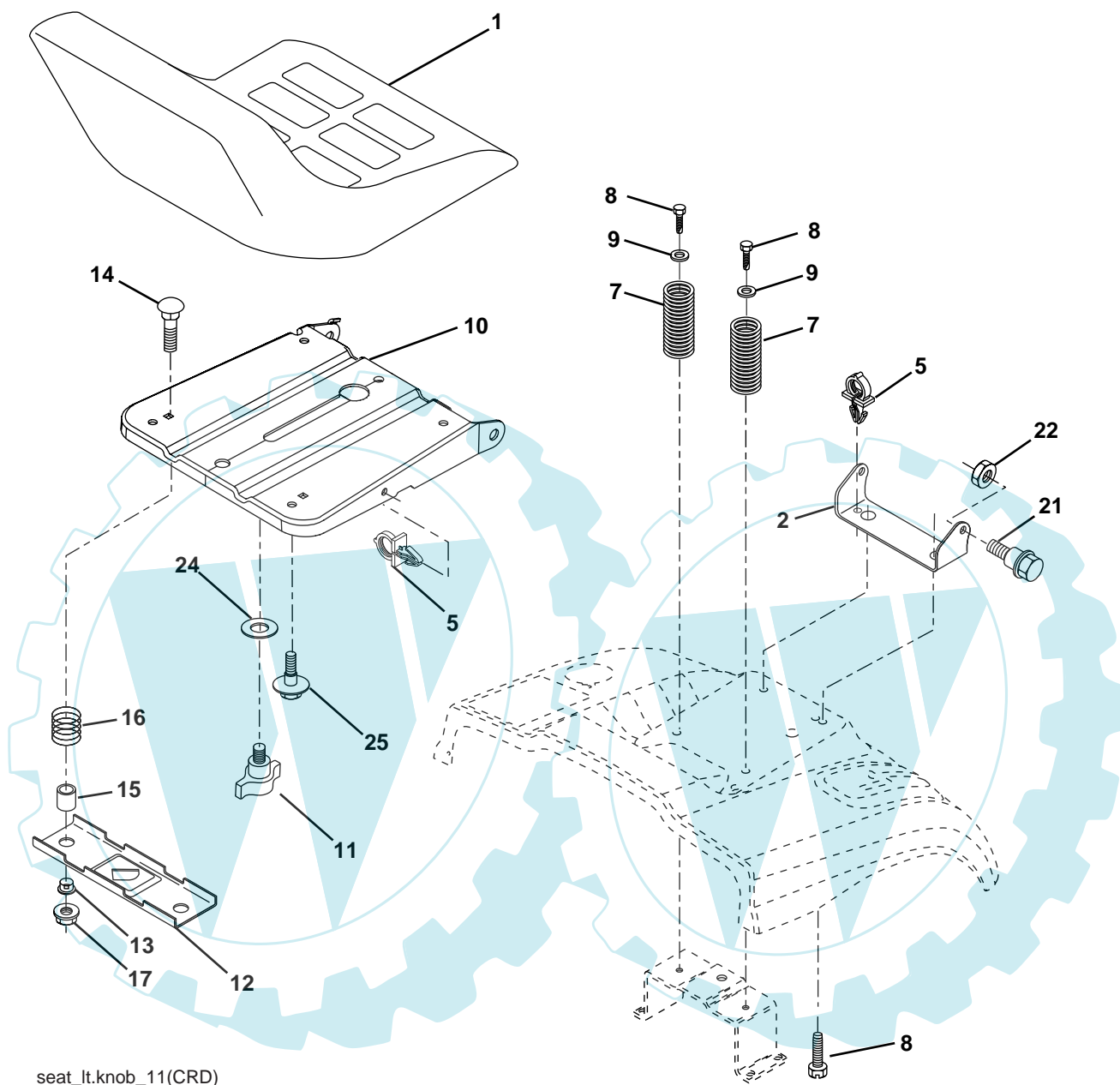

seat\_lt.knob\_11(CRD)

KEY NO.	PART NO.	DESCRIPTION
1	532 40 10-42	Seat
2	532 14 05-51	Bracket Pnt Pivot Seat (blk )
3	871 11 06-16	Bolt Fin Hex 3/8-16 unc x 1
4	819 13 16-10	Washer Flat 13/32 x 1 x 10 Ga.
5	532 14 50-06	Clip Push In Hinged
6	873 80 06-00	Nut Lock Hex 3/8-16 unc
7	532 12 41-81	Spring Seat Cprsn 2 250 Blk Zi
8	817 00 06-16	Screw 3/8-16 x 1-1/2
9	819 13 16-14	Washer 13/32 x 1 x 14 Ga.
10	532 19 55-30	Pan Pnt Seat (blk )
11	532 16 63-69	Knob Seat
12	532 17 46-48	Bracket Pnt Mounting Switch

KEY NO.	PART NO.	DESCRIPTION
13	532 12 12-48	Bushing Snap Blk Nyl 50 Id
14	872 05 04-12	Bolt Rdhd Sht Nk 1/4-20 x 1-1/2
15	532 13 43-00	Spacer Split
16	532 12 12-50	Spring Cprsn Plate SW 1.3 10 Ga.
17	532 12 39-76	Nut Lock 1/4 Lge Flg Gr. 5 Zinc
21	532 17 18-52	Bolt Shoulder 5/16-18 unc-2A
22	873 80 05-00	Nut Hex Lock w/Ins 5/16-18
24	819 17 19-12	Washer 17/32 x 1-3/16 x 12 Ga.
25	532 12 70-18	Bolt Shoulder 5/16-18 x 62

**NOTE:** All component dimensions given in U.S. inches.  
1 inch = 25.4 mm

# REPAIR PARTS

TRACTOR- -MODEL NO. LZ13592RBK (96061011900), PRODUCT NO. 960 61 01-19  
DECALS

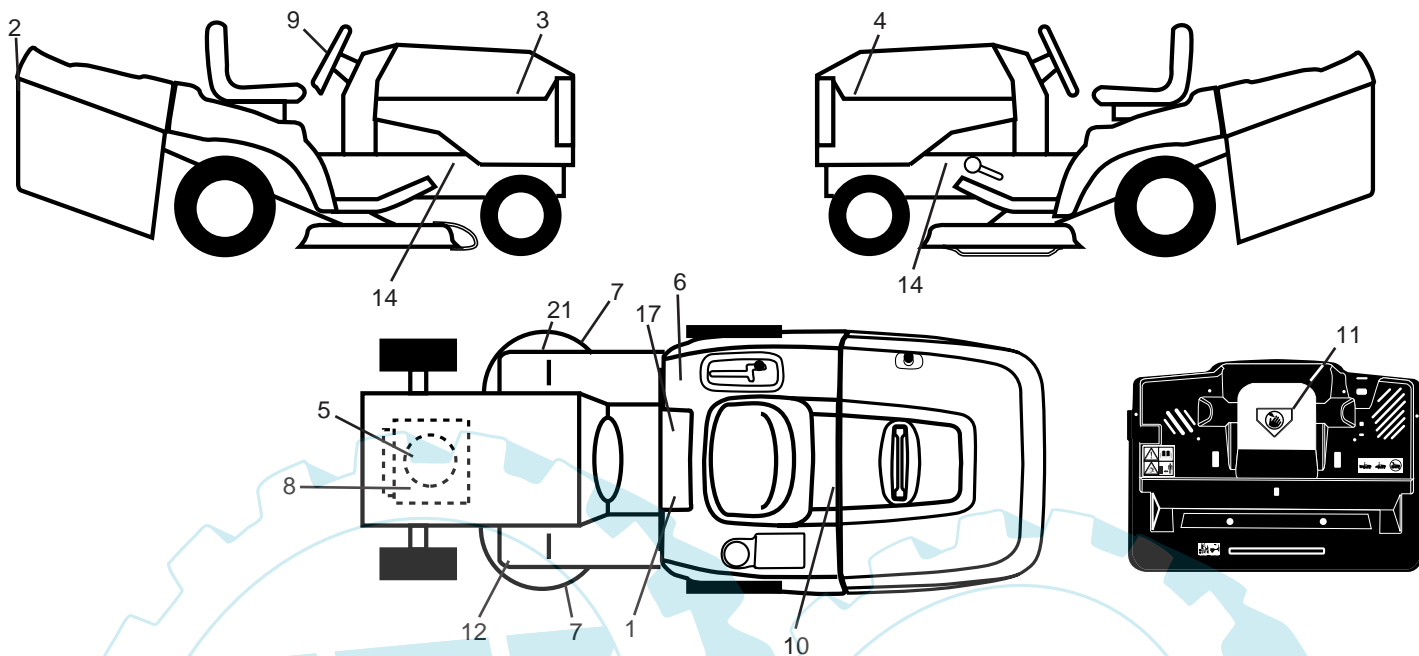

KEY NO.	PART NO.	DESCRIPTION
1	532 40 03-89	Decal, Warning Syms. CE
2	532 19 56-99	Decal, Fender
3	532 40 22-24	Decal, Hood RH
4	532 40 22-25	Decal, Hood LH
5	532 19 68-41	Decal, Warning Eng. Symbols
6	532 18 04-32	Decal, Fender 100 OB/CE
7	532 19 68-42	Decal, Cutfinger Symbols
8	532 18 94-55	Decal, Engine HP
9	532 19 56-98	Decal, Strg Whl
10	532 14 50-05	Decal, Bat Dan/Poi P/L Sym Wpn

KEY NO.	PART NO.	DESCRIPTION
11	532 18 21-66	Decal, Mower Cut Finger Symbol
12	532 15 97-37	Decal, Brake/Clutch Symbol Lt
14	532 15 97-36	Decal, Chassis Hot Muffler
17	532 14 08-37	Decal, Saddle Brake Parking
21	532 16 62-86	Decal, Hex Belt Sch 92 CRD
--	532 13 83-11	Decal, Lift Handle
--	532 18 10-90	Pad Footrest RH
--	532 18 10-91	Pad Footrest LH
--	532 40 08-65	Manual Operator's (Euro)
--	532 40 08-67	Manual Operator's (Scan)
--	532 40 23-95	Manual Parts

## WHEELS & TIRES

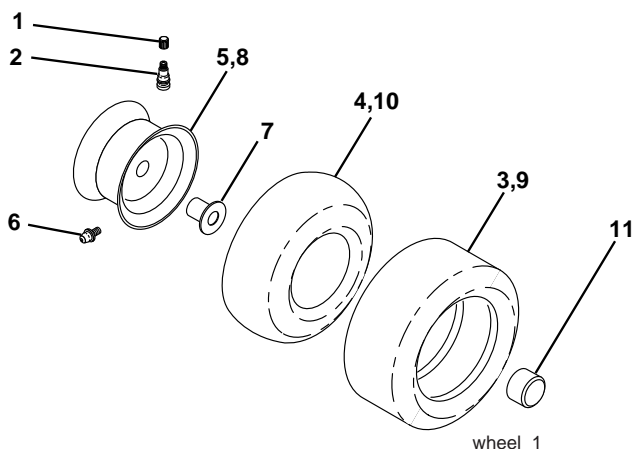

KEY NO.	PART NO.	DESCRIPTION
1	532 05 91-92	Cap Value Tire
2	532 06 51-39	Stem Valve
3	532 10 62-22	Tire F Ts 15 x 6 0 - 6 Service
4	532 05 99-04	Tube Inner Front #35060
5	532 18 33-37	Rim Asm 6" front Service
6	532 12 49-57	Fitting Grease
7	532 12 49-59	Bearing Flange
8	532 18 33-38	Rim Asm 8" rear Service
9	532 10 62-68	Tire R Ts 18 x 9.5-8 C. Service
10	532 12 49-26	Tube Rear 9 5 x 8 Service
11	532 17 50-39	Cap Axle Blk 1 50 x 1 00
--	532 14 43-34	Sealant, Tire (10 oz. tube)

**NOTE:** All component dimensions given in U.S. inches  
1 inch = 25.4 mm

# REPAIR PARTS

TRACTOR- -MODEL NO. LZ13592RBK (96061011900), PRODUCT NO. 960 61 01-19  
ENGINE

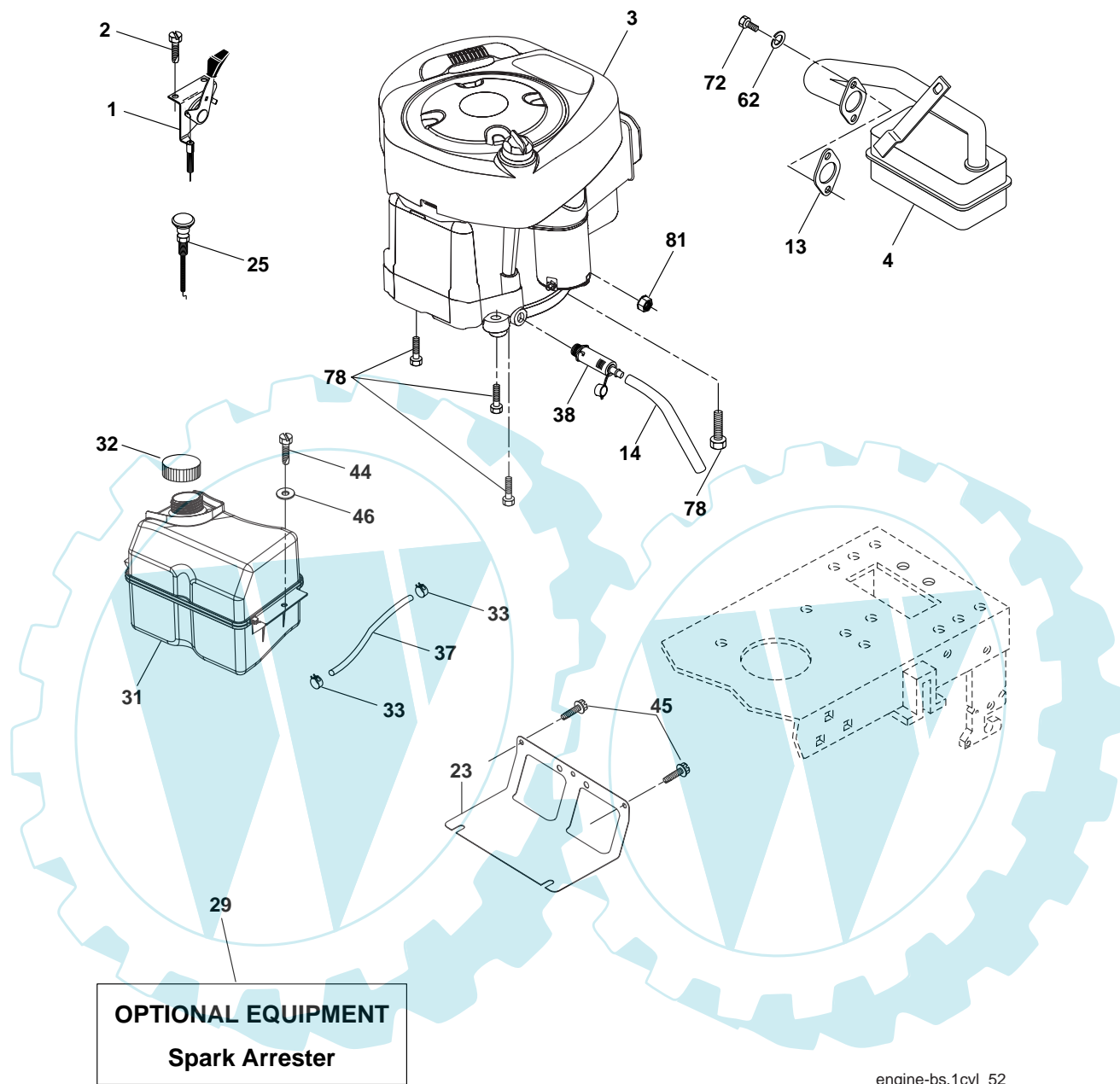

engine-bs.1cyl\_52

KEY NO.	PART NO.	DESCRIPTION
1	532 17 05-51	Control Throttle /Choke
2	817 72 04-08	Screw Hex Thd Cut 1/4-20 x 5/8 T
3	-----	Engine B&S Model 21B807 (Order Parts from Engine Manufacturer)
4	532 17 97-58	Muffler Exhaust
13	532 16 52-91	Gasket
14	532 14 84-56	Tube Drain Oil Easy
23	532 16 98-37	Shield Browning/Debris Guard
25	532 19 06-95	Control Choke
29	532 13 71-80	Arrestor Spark
31	532 18 55-34	Tank Fuel
32	532 19 77-25	Cap Asm Fule Top

KEY NO.	PART NO.	DESCRIPTION
33	532 12 34-87	Clamp Hose Blk
37	532 13 70-40	Line Fuel 20"
38	532 18 16-54	Plug Drain Oil Easy
44	817 67 04-12	Screw Hexwsh Thdrol 3/8-16 x 3/4
45	817 00 06-12	Screw 3/8-16 x 3/4
46	819 09 14-16	Washer 9/32 x 7/8 x 16 Ga.
62	810 04 05-00	Washer Lock Hvy HLCL Spr 5/16
72	532 19 23-34	Screw Socket Hd 5/16-18 x .75
78	817 06 06-20	Screw 3/8-16 x 1-1/4
81	873 51 04-00	Nut Keps Hex 1/4-20 unc

**NOTE:** All component dimensions given in U.S. inches  
1 inch = 25.4 mm

# REPAIR PARTS

TRACTOR- -MODEL NO. LZ13592RBK (96061011900), PRODUCT NO. 960 61 01-19  
MOWER LIFT

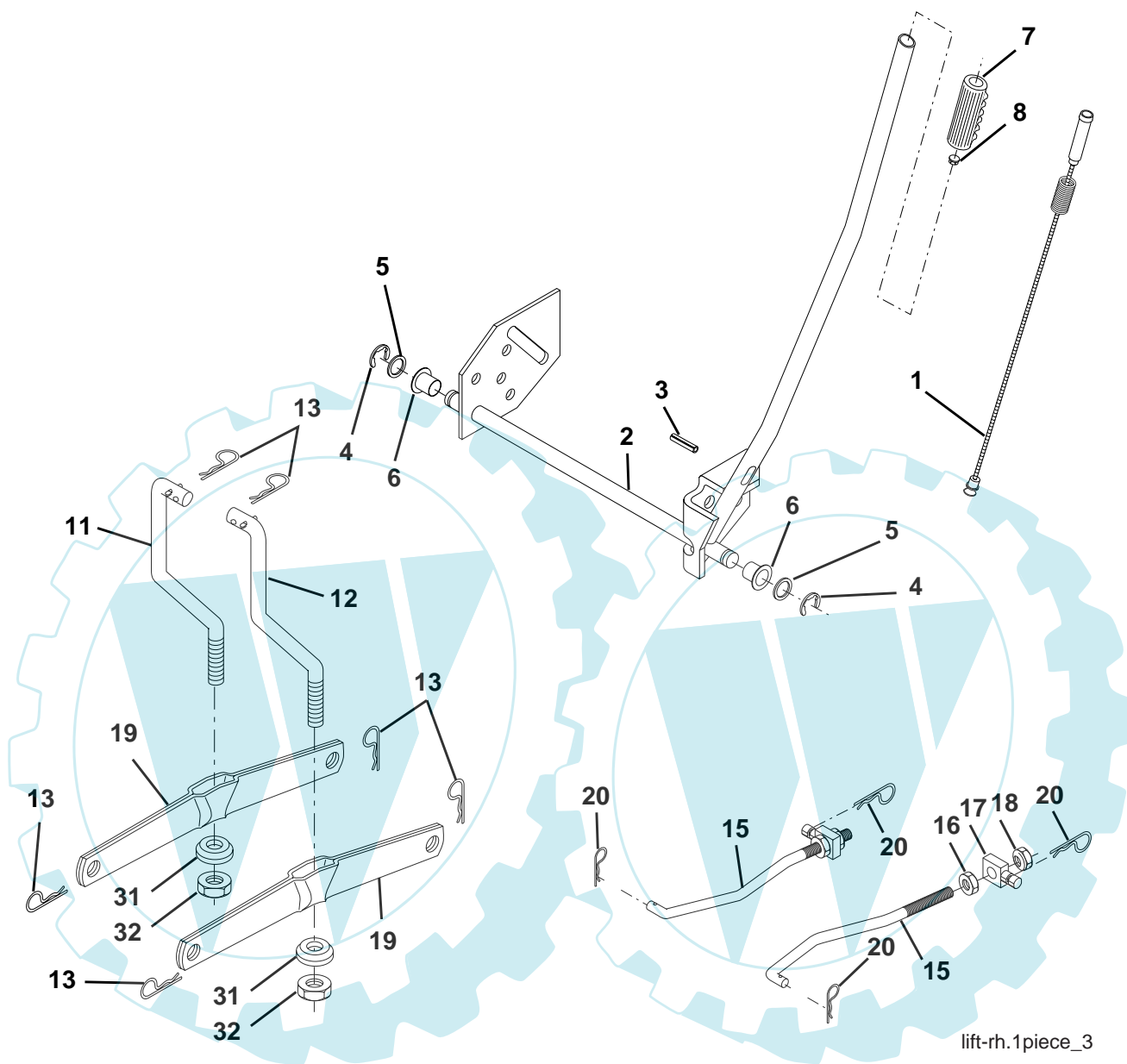

lift-rh.1piece\_3

KEY NO.	PART NO.	DESCRIPTION
1	532 19 84-17	Wire Asm Inner Spring Plunger
2	532 19 80-70	Shaft Asm. Lift
3	532 18 88-22	Pin Groove
4	812 00 00-02	E Ring #5133-62
5	819 21 16-21	Washer 21/32 x 1 x 21 Ga.
6	532 12 01-83	Bearing Nylon
7	532 10 94-13	Grip Handle Bicycle
8	532 12 45-26	Button Plunger Black
11	532 16 58-29	Link Asm Lift L.H.
12	532 16 58-31	Link Asm Lift R.H.
13	532 12 46-70	Retainer Spring

KEY NO.	PART NO.	DESCRIPTION
15	532 17 32-88	Link Front
16	873 35 08-00	Nut Jam Hex 1/2-13 unc
17	532 17 56-89	Trunnion Blk Zinc
18	873 80 08-00	Nut Lock w/Wsh 1/2-13 unc
19	532 13 98-68	Arm Suspension Mower
20	532 19 42-09	Retainer Spring
31	532 16 98-65	Bearing, Pvt. Lift.
32	873 54 06-00	Nut Crownlock 3/8-24

**NOTE:** All component dimensions given in U.S. inches  
1 inch = 25.4 mm

# REPAIR PARTS

TRACTOR- -MODEL NO. LZ13592RBK (96061011900), PRODUCT NO. 960 61 01-19  
MOWER

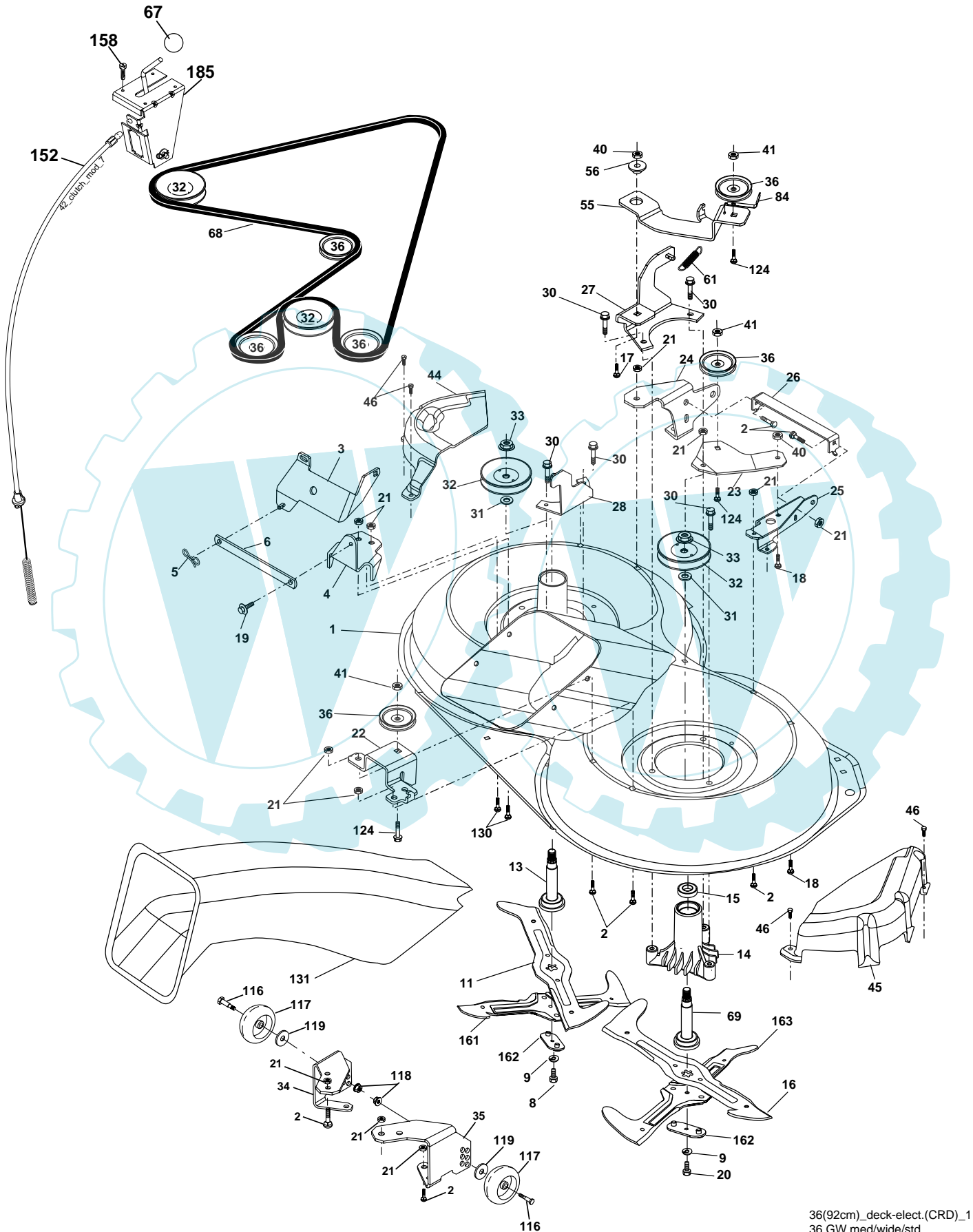



# REPAIR PARTS

TRACTOR- -MODEL NO. LZ13592RBK (96061011900), PRODUCT NO. 960 61 01-19  
MOWER

KEY NO.	PART NO.	DESCRIPTION	KEY NO.	PART NO.	DESCRIPTION
1	532 40 01-08	Housing Asm. Mower	40	873 68 06-00	Nut Crownlock 3/8-16 unc
2	872 14 05-06	Bolt Rdhd Sqnk 5/16-18 unc x 3/4	41	873 90 06-00	Nut Lock FLg 3/8-16 unc
3	532 16 55-69	Bracket Asm. S-Bar Chass	44	532 17 55-38	Cover Mandrel Lh
4	532 16 55-58	Bracket Bar Sway Deck	45	532 17 55-39	Cover Mandrel Rh
5	532 12 46-70	Retainer Spring	46	532 13 77-29	Screw Thd Roll 1/4-20 x 5/8
6	532 16 55-57	Bar Sway	55	532 19 94-98	Arm Idler
8	532 18 17-12	Bolt 3/8-24 x 1.25 Gr. 8 Patched	56	532 16 57-23	Spacer Retainer PM Mower
9	810 03 06-00	Washer Lock Hvy 3/8 Unplated	61	532 16 59-45	Spring Tension Belt
11	532 18 63-85	Blade 3-1 Lh	67	532 10 69-32	Knob Rd 3/8-16 Plstc Thds Blk
13	532 13 76-45	Shaft Asm. W/Lower Bearing	68	532 18 02-17	Hex-Belt 92 Mower
14	532 12 87-74	Housing Mandrel Vented (Machd)	69	532 16 54-82	Shaft Asm W/Lwr Brg Rh Thd CRD
15	532 11 04-85	Bearing Ball Mandrel	84	532 15 60-85	Keeper Belt Idler
16	532 18 63-86	Blade 3-1 Rh	116	532 18 42-19	Bolt Shoulder
17	872 14 06-10	Bolt Carriage 3/8-16 x 1-1/4	117	532 17 48-73	Wheel Gauge
18	872 11 06-06	Bolt Rdhd Sqnk 3/8-16 x 3/4	118	873 93 06-00	Nut Centerlock 3/8-16 unc
19	532 13 28-27	Bolt Shoulder 5/16-18 Thd Form	119	819 12 14-14	Washer 3/8 x 7/8 x 14 Ga.
20	532 18 17-13	Bolt 3/8-24 x 1.25 Gr.8 Ptch Lhthd	124	872 11 06-12	Bolt Carr Sh 3/8-16 x 1-1/2 Gr. 5
21	873 68 05-00	Nut Crown Lock 5/16-18	130	872 11 05-06	Bolt Rdhdsqnk 5/16-18 unc x 3/4
22	532 19 95-90	Bracket Idler Sprt	131	532 16 56-61	Chute Bagger CRD
23	532 16 54-46	Bracket Idler Sprt RF	152	532 17 60-74	Cable Clutch CRD Service
24	532 16 52-42	Bracket Suspension LF	158	817 72 04-08	Screw Hex Thdcut 1/4-20 x 5/8
25	532 16 52-44	Bracket Suspension RF	161	532 18 63-87	Blade Cross Lh 92
26	532 40 01-10	Brace Support Susp Frt CRD	162	532 18 08-78	Adpater Blade Cross
27	532 16 55-68	Bracket Asm. Susp RR	163	532 18 63-88	Blade Cross Rh 92
28	532 16 55-67	Bracket Asm. Susp LR	185	532 18 82-34	Head Asm Cable Clutch
30	532 17 39-84	Screw Thd Rolling Washer Head	--	532 18 18-57	Mandrel Asm Service
31	532 18 76-90	Washer Spacer	--	532 18 18-58	Mandrel Asm CRD Lh Threads SVC
32	532 15 35-31	Mandrel Pulleys 36 & 46	--	532 40 23-06	Replacement Mower Complete (Std. deck order separately gauge wheel components key nos. 116-119)
33	532 40 02-34	Nut Flg Top Lock			
34	532 40 01-07	Bracket Gauge Wheel Lf			
35	532 40 01-06	Bracket Gauge Wheel Rf			
36	532 14 67-63	Pulley Idler V-Groove Dim 4.25			

**NOTE:** All component dimensions given in U.S. inches  
1 inch = 25.4 mm

# REPAIR PARTS

TRACTOR- -MODEL NO. LZ13592RBK (96061011900), PRODUCT NO. 960 61 01-19  
BAGGER

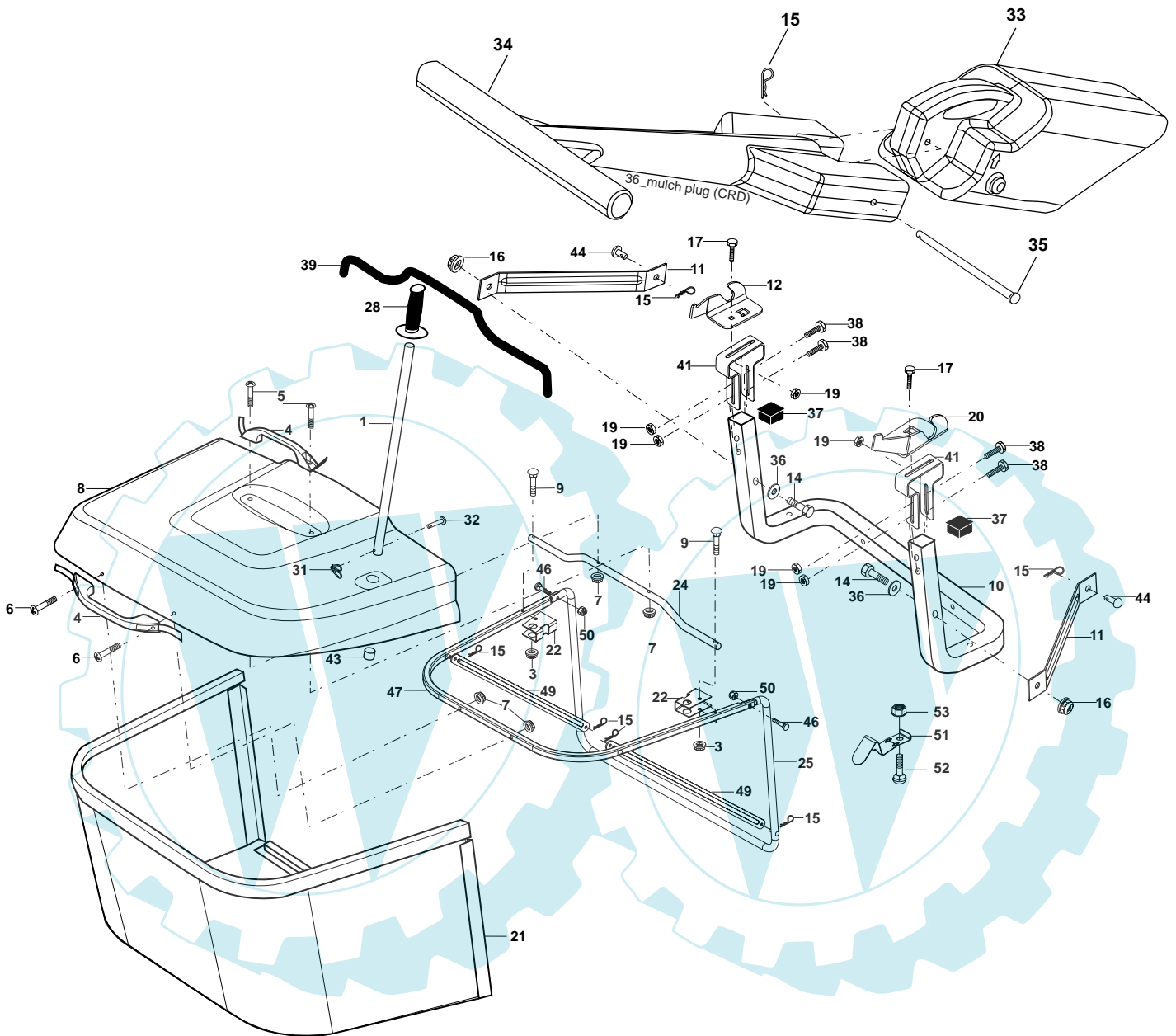

Bagger Asy (CRD)\_12

## REPAIR PARTS

TRACTOR- -MODEL NO. LZ13592RBK (96061011900), PRODUCT NO. 960 61 01-19  
BAGGER

KEY NO.	PART NO.	DESCRIPTION
1	532 16 52-49	Tube Handle Bagger CRD
3	532 12 39-76	Nut Lock 1/4 Lge Flg Gr. 5 Zinc
4	532 16 99-16	Handle Bagger w/Lvrs Gr. 5 Zinc
5	874 98 10-24	Screw Pan Head #10-24 x 1.50 Blk
6	874 98 10-32	Screw Pan Hd
7	873 40 10-00	Nut Wiz Lock Hex Serr/Hd #10-24
8	532 18 13-54	Cover Bagger Steel
9	872 14 04-18	Bolt Carriage 1/4-20 x 2.25d x Gr.5
10	532 18 12-82	Tube Support Bagger CRD
11	532 16 57-19	Bracket Support Upper Bag CRD
12	532 18 88-48	Bracket Pivot LH
14	874 52 06-36	Bolt Fin Hex 3/8-16 x 2-1/4 Gr. 5
15	532 12 46-70	Retainer Spring
16	873 90 06-00	Nut Latch Flg. 3/8-16 unc
17	872 14 05-06	Bolt Rdhd Sht Sqnk 5/16-18 unc x 3/4
19	873 90 05-00	Nut Lock Hex Flange 5/16-18
20	532 18 88-47	Bracket Pivot RH
21	532 19 38-38	Bag Asm CRD
22	532 16 57-81	Bracket Side Bagger CRD
24	532 16 57-83	Tube Pivot Bagger CRD
25	532 19 37-05	Tube Front Bagger CRD
28	532 16 57-87	Grip Handle Black
31	532 16 94-84	Retainer Clip
32	532 12 68-75	Rivet Rd Hd Drilled 3/8 Dia.
33	532 16 55-71	Plug Mulcher
34	532 16 55-70	Handle Mulcher
35	532 16 55-72	Pin Mulcher
36	819 13 20-12	Washer 13/32 x 1-1/4 x 12 Ga.
37	532 17 54-01	Plug Support Bagger CRD
38	872 01 05-20	Bolt 5/16-18 x 2-1/2
39	532 18 09-85	Seal Trim 37"
41	532 16 96-83	Bracket Vert Adj Bagger CRD
43	532 17 40-83	Plug Tubing End
44	532 19 33-12	Pin Clevis 3/8 x 11/16
46	872 11 05-10	Bolt Carr. 5/16-18 x 1-1/4 Gr. 5
47	532 19 37-04	Tube Upper Bagger
49	532 19 33-05	Spreader Bar Bagger
50	873 80 05-00	Nut Lock Hex W/Insert 5/16-18 unc
51	532 19 99-03	Latch Spring
52	872 14 04-06	Bolt Rdhd Sqnk 1/4-20 x 3/4 Gr. 5
53	873 51 04-00	Nut Keps Hex 1/4-20 unc

**NOTE:** All component dimensions given in U.S. inches  
1 inch = 25.4 mm

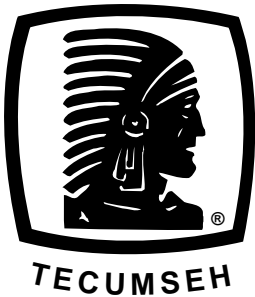

# SERVICE POLICY WARRANTY

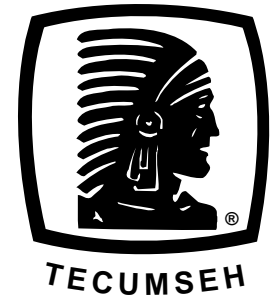

Issued January 1980  
Revised January 1991

## LIMITED WARRANTIES FOR NEW PEERLESS GEAR POWER TRAIN COMPONENTS

### A. Products Warranted

Peerless Gear and Machine Division of Tecumseh Products Company ("Tecumseh"), subject to the limitations contained below, will, at its option, repair or replace, without charge for parts or labor only, any part of a new Power Train Component (which as used herein means and includes the transaxle, gear box, transmission, differential and right angle drives, and any part of the Power Train Component), EXCEPT any new Power Train Component incorporated in equipment used for commercial or rental purposes, which is found upon examination by any Tecumseh Authorized Service Outlet or by Tecumseh's factory in Grafton, Wisconsin, to be DEFECTIVE IN MATERIAL AND/OR WORKMANSHIP if received by Tecumseh or a Tecumseh Authorized Service Outlet for such examination within TWO YEARS from the date of sale to the original consumer purchaser of Peerless Series 820, 900, 910, 915, 920, 930 transaxles and Series 1100 angle drive and ONE YEAR for all other Peerless products. New Power Train Components incorporated in equipment used for commercial purposes are warranted in the same manner and to the same extent EXCEPT such Power Train Components are warranted for NINETY (90) DAYS ONLY, and must be received by Tecumseh or by a Tecumseh Authorized Service Outlet for such examination within 90 days from the date of sale to the original purchaser. New Power Train Components Incorporated in equipment used for rental purposes are warranted in the same manner and to the same extent EXCEPT such Power Train Components are warranted for THIRTY (30) DAYS ONLY, and must be received by Tecumseh or a Tecumseh Authorized Service Outlet within 30 days from the date of sale to the original purchaser.

### B. Products And Items Not Warranted

1. Alterations or Modifications of Power Train Components.
2. Accidents, Normal Maintenance, Failure to follow the Original Equipment Manufacturer's Manual.

This warranty covers only parts of new Power Train Components which are found upon examination to be defective in material or workmanship as delivered to the original purchaser. This warranty does not cover defects caused by depreciation or damage caused by normal wear, accidents, improper maintenance, improper use or abuse of the product, failure to follow the instructions contained in an Instruction Manual for the operation of the Power Train Component and parts. The cost of normal maintenance and replacement of service items which are not defective shall be paid for by the original purchaser.

### C. Securing Warranty Service

Warranty service can be arranged for by contacting either a Tecumseh Authorized Service Outlet (any Tecumseh Registered Service Dealer, Tecumseh Authorized Service Distributor, or Tecumseh Central Warehouse Distributor) or by contacting Tecumseh, c/o Service Manager, Engine and Transmission Group Service Division, 900 North Street, Grafton, Wisconsin 53024. Warranty service can only be performed by a Tecumseh Authorized Service Outlet or by Tecumseh at its factory in Grafton, Wisconsin. At the time of requesting warranty service, evidence must be presented of the date of sale to the original purchaser. The purchaser shall pay any charges for making service calls and/or for transporting the product to and from the place where the inspection and/or warranty work is performed. The purchaser shall be responsible for any damage or loss incurred in connection with the transportation of Power Train Components and/or part(s) of the Power Train Components submitted for inspection and/or warranty work.

### D. Limitation of Damages and Implied Warranties

The foregoing EXPRESSED WARRANTY IS IN LIEU OF ALL OTHER EXPRESS WARRANTIES. Neither Tecumseh nor any of its affiliates makes any warranties, representations or promises, written or oral, as to the quality of the Power Train Component or any of its parts, other than as set forth herein.

ANY IMPLIED WARRANTY OF MERCHANTABILITY OR FITNESS FOR A PARTICULAR PURPOSE, TO THE EXTENT THAT EITHER MAY APPLY TO ANY PART(S) OF POWER TRAIN COMPONENTS, SHALL BE LIMITED IN DURATION TO THE PERIODS OF THE EXPRESSED WARRANTIES DEFINED IN PARAGRAPH A HEREOF. IN NO EVENT WILL TECUMSEH BE LIABLE FOR ANY INCIDENTAL, CONSEQUENTIAL OR SPECIAL DAMAGES AND/OR EXPENSES. Some states do not allow limitations on how long an implied warranty lasts or the exclusion or limitation of incidental or consequential damages, so the above limitation(s) or exclusion(s) may not apply to you. This warranty gives you specific legal rights and you may also have other legal rights which vary from state to state.

### E. No Dealer Warranty

Tecumseh neither assumes nor authorizes any other person, natural or corporate, to assume for Tecumseh any other obligations or liabilities in connection with or with respect to any part(s) of a Power Train Component. The seller or dealer of part(s) of a Power Train Component has no authority, whatsoever, to make any representations or promises on behalf of Tecumseh or to modify the terms or limitations of Tecumseh's warranty in any way.

LAZER®

Ihr Ersatzteilspezialist im Internet